

COMPACT FLANGES NORSOK L-005 EDITION 2, MAY 2006

DIMENSION CLASS 2500

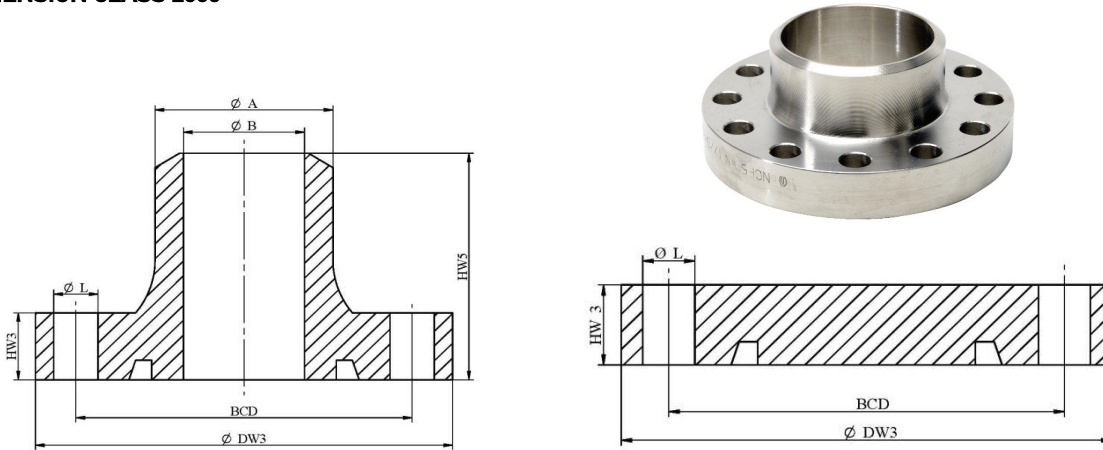

5
Flanges /
Connectors

DN	NPS	DW3 [mm]	HW3 [mm]	HW5 [mm]	BCD [mm]	A [mm]	B [mm]	NUMBER OF HOLES	DIAM. [inch]
15	1/2"	93	20	51	67.3	21.3	15.8-6.4	4	1/2"
20	3/4"	98	20	53	72.7	26.7	21.0-11.1	4	1/2"
25	1"	105	20	56	79.4	33.4	26.6-15.2	4	1/2"
40	1 1/2"	121	23	64	95.3	48.3	40.9-23.3	8	1/2"
50	2"	147	27	72	116.2	60.3	52.5-31.9	8	5/8"
65	2 1/2"	179	32	81	141.6	73.0	59.0-41.0	8	3/4"
80	3"	209	36	85	166.3	88.9	77.9-53.9	8	7/8"
100	4"	248	44	95	200.4	114.3	97.2-69.9	8	1"
125	5"	278	50	106	230.2	141.3	109.5-91.3	12	1"
150	6"	322	58	120	268.8	168.3	146.4-108.3	12	1-1/8"
200	8"	408	72	145	343.7	219.1	188.9-147.1	12	1-3/8"
250	10"	485	88	172	415	273.1	242.9-183.1	16	1-1/2"
300	12"	564	99	195	483.2	323.9	288.9-213.9	16	1-3/4"
350	14"	618	108	211	531.2	355.6	317.5-245.6	16	1-7/8"
400	16"	718	125	238	615.1	406.4	363.5-276.4	16	2-1/4"
450	18"	780	136	260	676.3	457.2	409.4-317.2	16	2-1/4"
500	20"	849	147	282	735	508.0	455.6-348.0	16	2-1/2"
550	22"	958	163	310	821.8	558.8	450.8-388.8	16	3"
600	24"	1039	176	334	891.3	609.6	504.9-419.6	16	3-1/4"

Calculated weights of flanges are based on nominal dimensions given in Annex A and density equal to 7,85 kg/dm3.